

Model MCD-19 Remaining Change Detection Sensor

PATENTED



Model List	Operation Status
MCD-19	Normally open
MCD-191	Normally closed

Application

- Remaining tokens detection for token exchangers - Remaining coins detection for ATMs
- Remaining change detection for POS, automatic vending machines, automatic ticket vending machines
- Remaining change detection for automatic payment machines at parking lots or highway tollgates

Features

- Thin profile means the unit can be mounted in a space as little as 14mm high, under the coin trays.
- A locking connector securely prevents disconnection of connectors caused by wire routing problems or vibration.
- The unit is equipped with a LED display for clear indication of operation status.
- Detection distance of 19 mm for 1-yen coins (aluminum).
- Optimum for detecting all coin materials including aluminum, copper, and copper alloys.
- Not affected by residual dust in the coin receptacles.
- Metal fittings can be directly attached to the unit to adapt it to any mounting requirement.

Rating/Performance

Model	MCD-19	MCD-191
Detection Surface	Upper side detection	
Detection Distance	19.0 mm ± 10 % (With detection target of 1 yen coin)	
Hysteresis	10 % or less of the detection distance	
Set Distance	0 to 14 mm	
Power Supply Voltage	12 V to 24 V DC (Operating voltage range: 10 V to 30 V DC)	
Current Consumption	20 mA DC or less	
Output	Nch MOSFET Open drain 30 V DC, 100 mA DC or less	
Output Residual Voltage	0.5 V DC or less (Load current 100 mA DC)	
Input	Reset input terminal is used, 2 ms or more to GND: short-circuit	
Operation Status	Normally open (ON output when detecting)	Normally closed (OFF output when detecting)
Operation Indicator	Red LED (ON when coin is detected)	
Response Speed	Within 400 ms	
Temperature Range	-10 to 60 °C (At storage: -25 to 65 °C storage temperature Range) (Without dew condensation or icing)	
Humidity Range	85 % RH or less (85 % RH or less storage humidity Range) (Without dew condensation)	
Dielectric Strength	500 V AC for 1 minute (Between the live part and case)	
Insulation Resistance	50 MΩ or more at 500 V DC megger (Between the live part and case)	
Vibration Resistance	10 to 55 Hz, 1.5 mm double amplitude in X, Y and Z directions for 2 hours each (at power off)	
Shock Resistance	500 m/s ² (Approx. 50 G) in X, Y and Z directions 3 times each (at power off)	
Protection	IP50	
Case Material	Case : Glass reinforced ABS resin / Model indication part: ABS resin	
Connector	Connector : SM04B-GHS-TB(4-pin) (from J.S.T. Mfg. Co., Ltd.) [Connections] Housing : GHR-04V-S, Contact : SSSL-002T-P0.2 (from J.S.T. Mfg. Co., Ltd.)	
Weight	Approx. 41 g	
Options (Sold Separately)	Connector harness : CNH-GHR4S28-3B	

Typical Values

With the centers of the coin and the detection surface aligned, move the coin in a vertical direction toward the detection surface (referential surface) and regard the position where the output switches ON as the detection distance.

Type of coin and detection distance	
1-Cent (US)	18.3 mm
10-Cent (US)	17.7 mm
1 yen coin (Aluminum)	19.0 mm
5 yen coin (Brass)	19.8 mm
10 yen coin (Bronze)	20.5 mm
50 yen coin (Cupronickel)	19.4 mm
100 yen coin (Cupronickel)	19.8 mm
500 yen coin (Nickel silver)	21.7 mm

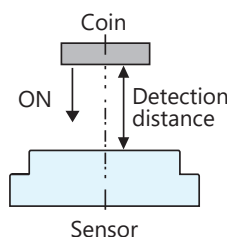
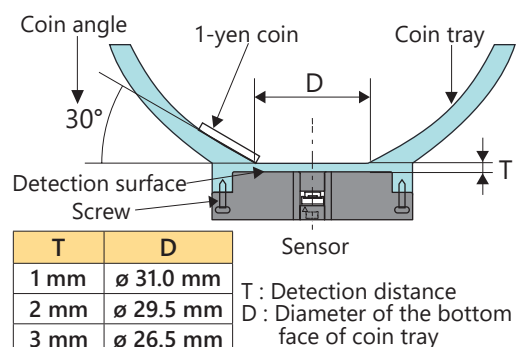
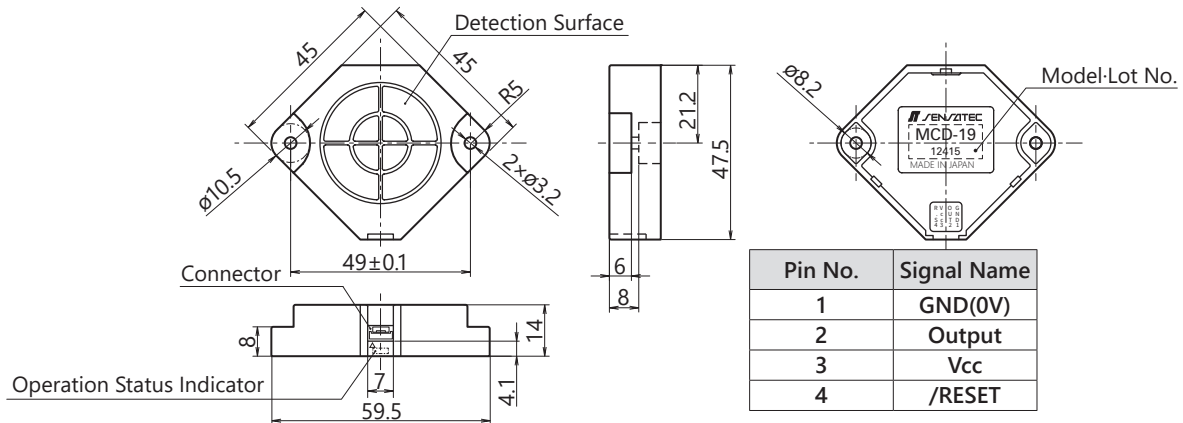

Diagram of coin tray (Typical)



*Other coin denominations are supported. Consult us for details.

Outline Dimensions



Output Circuit

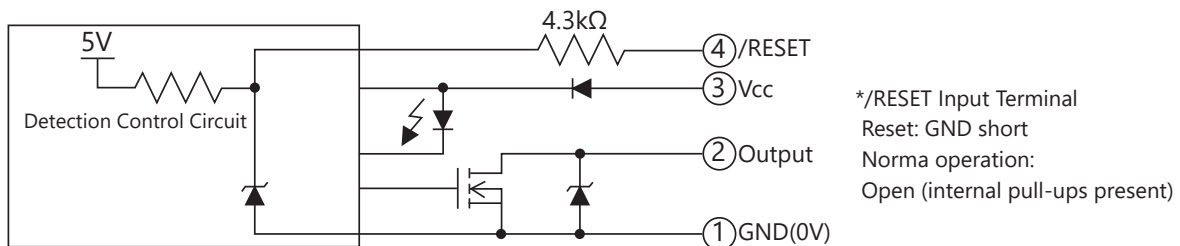

* If a distance detection error occurs, due to lightning strike interference for example, perform input reset to restore normal operation.

Characteristics Graph (Typical Example)

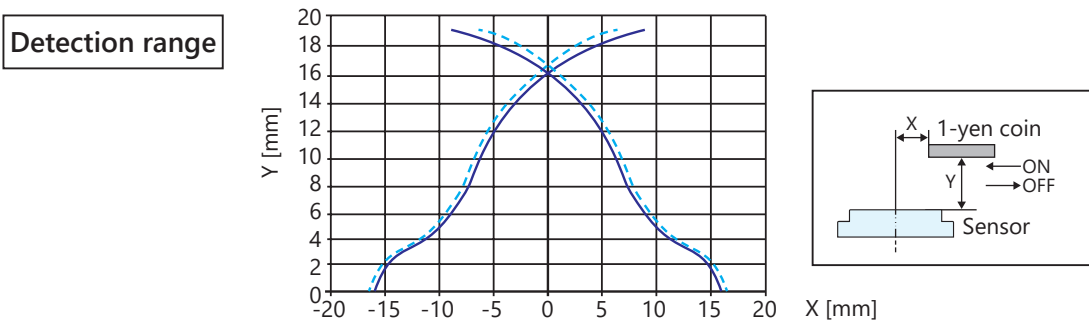

Precautions During Use

- When metallic objects are close to the detection field, to avoid malfunctions, position the sensor as follows.
- When both fixed and movable metal obstructions are nearby, position the sensor at the distance of, or more than the nearest metal object. In the example on the left, the sensor is positioned at least 10mm from the fixed metal obstruction (see Fig.i). This should eliminate interference caused by other metal objects further away.

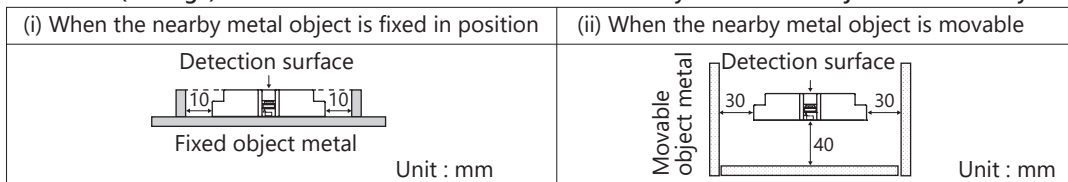

- When a number sensors are used, position them at 180 mm centers to avoid mutual interference.
- An abrupt temperature change can cause malfunctions. Avoid actions that cause temperature change, such as blowing with heated air.
- Remove any coins from the detection surface before power ON or resetting inputs.
- For approximately 2 seconds from power ON or input reset, coins on the detection surface can affect detection distance due to the initial surrounding environment check. Remove any coins, and wait for 2 seconds to recover normal operation. If the problem persists, perform an input reset.
- Ferromagnetic materials such as ferrite near the sensor can cause malfunctions.
- LED turns ON when there is detection with or without output.
- For mounting, use M3 screws. Always use plain washers to tighten the case and use a torque of 0.5 N·m max. The screws can be oriented either up or down.
- Washers to use: up to 10 mm dia. (detection side), Up to 8 mm dia. (opposite side)
- Any coin approaching at a very slow (reference speed: 3 mm/s or lower) cannot be detected.
- Mechanical stress on the detection surface can cause malfunctions.
- For other precautions, refer to "General Precautions" for inductive sensors.