

Model LLPS-3 Horizontal Mounting Type Capacitive Water Level Sensor

PATENTED



Model List	Case Material	Operation Status	Frequency
LLPS-3A	Syndiotactic polystyrene with glass (Ideal for the use in environments where organic solvent are used)	Normally open	Standard
LLPS-3B			1st Different
LLPS-3C			2nd Different
LLPS-31A		Normally closed	Standard
LLPS-31B			1st Different
LLPS-31C			2nd Different

Application

- Water level control for domestic tap water.
- Water level control for boiling water in water heaters.

Features

- An side Installation ultra-compact capacitive type water level sensor.
- Directly detects boiling water in coffee servers or vending machines.
- Controls water level of a single tank at three level points, by using three sensors that use different frequencies.
- Sensing electrode erosion is prevented by using a polarization prevention capacitor.
- Equipped with a status indicator for easy operation check.
- Complies with the Food Sanitation Act.

Rating/Performance

Model	LLPS-3*	LLPS-31*
Standard Detection Target	Tap water, including boiling detection	
Withstand Pressure Resistance	0.3 Mpa (At atmospheric pressure outside tank : 0.1 Mpa)	
Tank Thickness at Sensor Mounting Point	1 to 2.5 mm (When using the standard M10 SUS304 mounting nut)	
Power Supply Voltage	12 V to 24 V DC (Operating voltage range : 10.8 V to 26.4 V DC)	
Current Consumption	15 mA DC or less	
Output	NPN transistor open collector 30 V DC, 50 mA DC or less	
Output Residual Voltage	1 V DC or less (Load current 50 mA DC at cable 1 m)	
Operation Status	Normally open (ON output when detecting)	Normally closed (OFF output when detecting)
Operation Indication	Orange LED (Lit when the output is ON)	
Response Time	50 ms max	
Temperature Range	-20 to 100 °C (-20 to 100 °C storage temperature range) (Without dew condensation or icing)	
Humidity Range	95 % RH or less (95 % RH or less during storage humidity range) (Without dew condensation)	
Dielectric Strength	500 V AC for 1 minute (Between live parts and the mounting nuts)	
Insulation Resistance	50 MΩ or more at 500 V DC megger (Between live parts and the mounting nuts)	
Vibration Resistance	10 to 55 Hz, 1.5 mm double amplitude in X, Y and Z directions for 2 hours each (at power off)	
Shock Resistance	500 m/s ² (Approx. 50 G) in X, Y and Z directions 10 times each (at power off)	
Protection	IP 67	
Material	Case cover : SPS resin with glass, Detection electrode : SUS304 [Accessories] M10-Nut : SUS304, O-ring : Φ11 W2.4mm, Silicone rubber The materials used in parts that come into direct contact with water/moisture conform to "Standards for Food Additives" (Positive List System, to be effective on June 1, 2025) in Japan, defined under the Japan Food Sanitation Act.	
Cable	ø3, 3-core round cord of 0.15 mm ² and insulation 0.9 mm and 1 m in length (Oil and heat resistant vinyl)	
Weight	Approx. 34 g	

Dimensions

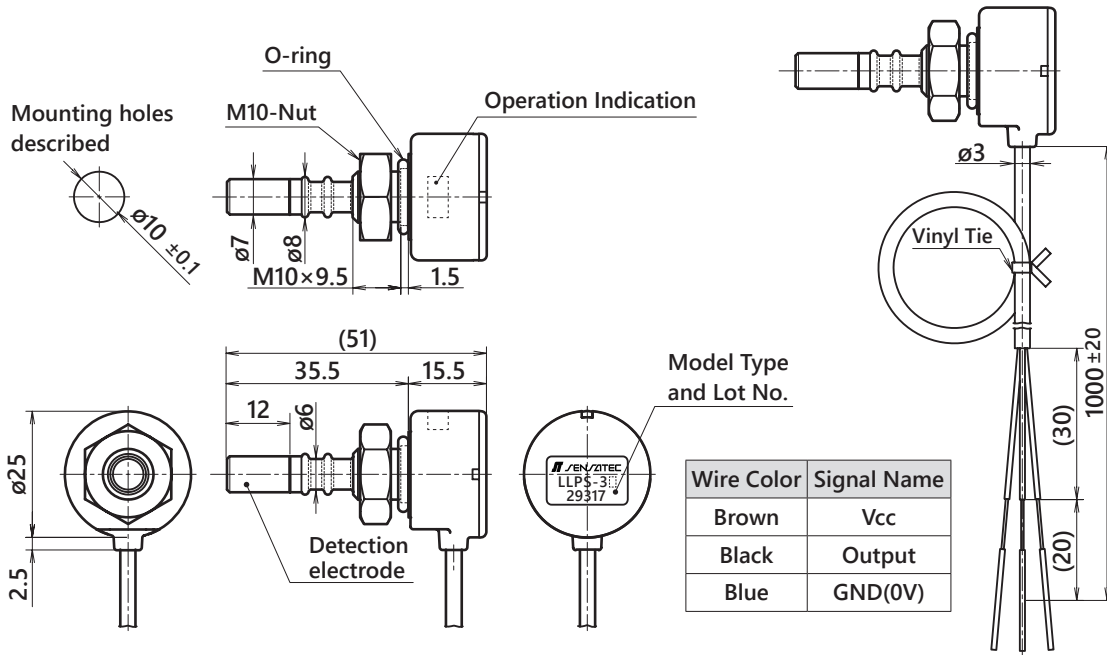

Output Circuit

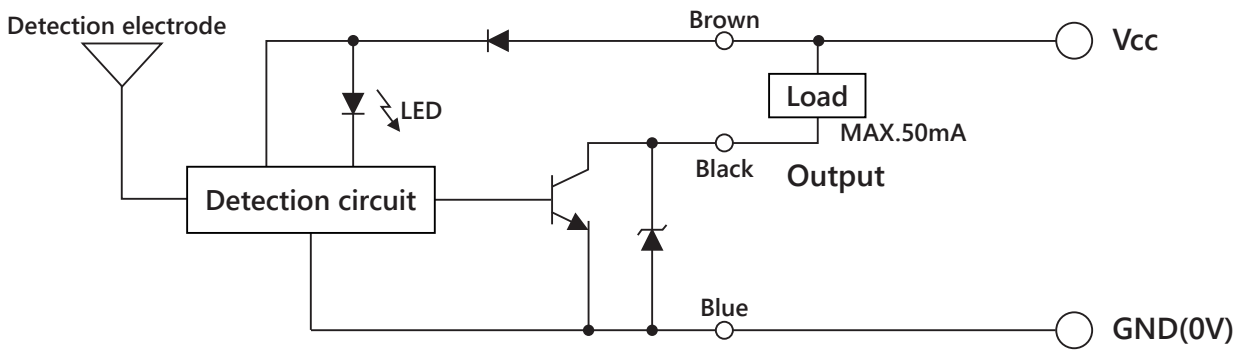

Precautions During Use

1. This sensor is designed to directly detect the water level of tap water and boiling water in water heaters for tap water. To detect water level of pure water and purified water, use LLPS-2L Series.
2. For other precautions, refer to "Precautions During Use" for next page.

Precautions During Use

- 1** A. When the detection electrode comes into contact with water, this sensor detects the capacitance of the detection electrode based on the earth ground or GND (0V) of the power supply. Therefore, if the capacitance of the tank water (detection target) to the earth ground or the power supply GND (0V) is small (less than 50pF), the water level may not be detected correctly.

For example, the following cases are applicable.

- ① When the capacity of water in the tank is small (capacity 1.5 m³ or less) and the material of the tank is an insulator such as plastic.
- ② The capacity of water in the tank is small (capacity 1.5 m³ or less), and the material of the tank is metal. However, when the tank itself is "electrically floating" and the capacitance between the tank and the earth ground is less than about 2,000 pF.

In this case, attach a conductive metal sheet of [50 x (T + 1)] mm square or more to the outer wall surface of the plastic tank. (However, tank thickness: T [mm])

Next, connect the metal sheet to the sensor power supply GND line (0V) or a housing with large conductivity (to the ground) with a lead wire. This connection increases the capacitance of the water in the tank to the earth ground, making it easier to detect the water level with this sensor.

Connect this lead wire and the metal sheet on the outer wall of the tank more securely even for a long period of time. The installation level of the metal sheet attached to the outer wall of the tank should be at the same level as the sensor, or below it. If the detected liquid is acidic or alkaline, or if it is used in a sulfur gas atmosphere, the contact part may form an insulating film on the metal surface due to oxidation, corrosion or sulfurization, resulting in poor contact.

When using in such a detected liquid or atmosphere, make a decision on use after fully evaluating the conditions of use.

- B.** In the application of lower limit water level detection of the tank, when the amount of water is extremely small, the capacitance of the water to be detected is small and correct detection may not be possible. In this case, make the outer wall of the tank only the part where the lower limit water level is reached metal, and attach the sensor there.

With this mounting method, the capacitance increases in proportion to the area facing the metal part and the internal water, making it easier for the sensor to detect even a small amount of liquid.

Then, the tank wall with metal surface, GND (0V) of the sensor, and the metal part of the large housing of the equipment are electrically connected outside the tank with lead wires. By electrically short-circuiting the tank wall with metal surface and the detection electrode with water, it is possible to generate a large capacitance between the detection electrode and the tank wall with metal surface to detect the water level.

As another method, it is easier to detect by using the LLPS-2L series, which has a long detection electrode and high detection sensitivity.

If detection is difficult with LLPS-3A, please consider the LLPS-2L series.

- 2** LLPS-3 is a sensor that detects the water level of general tap water and boiling water in a water heater. For detecting the water level of general tap water containing impurities other than pure water and purified water, the LLPS-3 series, which has a short detection electrode and has little effect on the detection electrode such as sediment, is suitable.

The LLPS-2L series can detect water with very few impurities such as pure water, purified water, and distilled water, in addition to general tap water and its boiling water.

On the other hand, the LLPS-3 series cannot detect water with very few impurities such as pure water, purified water, and distilled water.

- 3** When used in a water heater for a long period of time, the lime and sludge contained in the water are gradually concentrated and grow.

If the concentrated impurities accumulate between the inner wall of the tank and the detection electrode, the sensor may not operate normally. Be sure to clean the inside of the tank regularly to remove sediment.

- 4** This sensor cannot detect the level of liquids with a very small relative permittivity such as ice, alcohol and oil, as well as powders and particles other than water.

If you want to detect such liquids and powders, please contact us.

- 5** This sensor may not be able to detect liquids that are high in highly conductive substances (salts, acids, alkalis), surfactants and sticky substances.

This liquid causes the detection electrode and the inner wall of the tank to be electrically short-circuited, which interferes with the normal operation of the sensor.

Also, when the liquid is acidic or alkaline, the detection electrode and mounting M10 nut may corrode.

For these reasons, be sure to evaluate the sensor in the actual usage environment before using it.

Precautions During Use

- 6** In the following cases, use different frequency products in combination to avoid sensor malfunction due to mutual interference:
- When using multiple sensors in the same tank
 - When using multiple sensors for the same liquid to be detected
 - When the liquid to be detected is separated into multiple tanks in which the sensor is used, but the tanks are electrically connected to each other
 - When the liquid to be detected is separated into multiple tanks in which the sensor is used, and the tanks are electrically separated from each other, but the tanks are coupled with each other with a capacitance of 100 pF or more

7 About mounting

- This sensor needs to be mounted horizontally.
- Use it by inserting the detection electrode horizontally from the side of the tank etc.
Mount the sensor body, O-ring, wall surface of the tank, and nut in this order.

Wall of the container where the sensor will be mounted

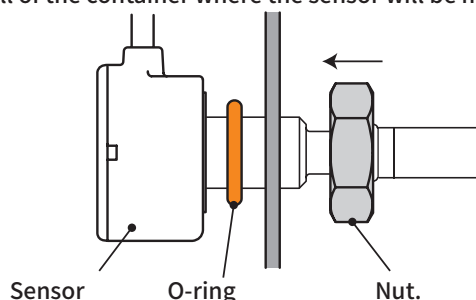

- If the sensor body cannot be mounted horizontally (the detection electrode faces upward or downward), mount the detection electrode (size : diameter $\Phi 7$) so that it is immersed in water as follows.
 1. LLPS-3 has a length of 5 mm or more
 2. LLPS-2 has a length of 15 mm or more

As shown above, stable detection results can be obtained by mounting the detection electrodes so that they are sufficiently immersed in water.

If the sensor is mounted on the bottom of the container with the detection electrode facing up, evaluate the pressure resistance used, the effect of sediment, and the contents of **1** (2) above.

Also, be aware that if conductive deposits or viscous liquid cause the detection electrode and the metal tank to be electrically connected, the output of the sensor will be poor.
- Ensure the separation between the detection electrode and the inner wall surface of the tank as shown in the table below.

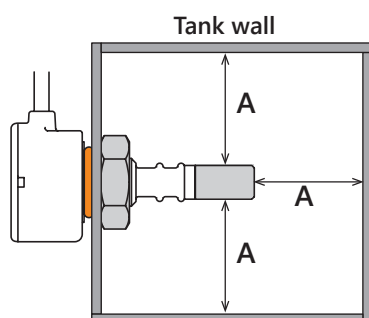

Model	Separation A (mm)
LLPS- 3 *	20 or more
LLPS - 2L *	30 or more

This separation is to prevent malfunction due to electrical short circuit occurring because the sediment between the detection electrode and the inner wall of the metal tank causes a bridge between the electrode and the inner wall of the tank. Even in the case of plastic tanks, ensure this separation to facilitate the work of removing sediment during regular cleaning.

- 8** Since the detection electrode is electrically connected to the sensor circuit, do not apply a voltage higher than the rated power supply voltage to the electrode.
- Also, ensure sufficient insulation resistance and dielectric strength between the liquid to be detected and the power supply at the DC power supply section of the sensor.

Precautions During Use

- 9** Tighten the M10 nut for mounting with a torque of 1.3 N · m (13.3 kgf · cm) or less.
When mounting, hold the case of the sensor body and tighten it without holding the cable.
Be sure to attach the O-ring (Φ11 / W2.4mm / silicone rubber) to the outside of the tank and the M10 nut to the inside of the tank.
Foreign matter caught between the O-ring and the outer wall of the tank or twisting of the O-ring may reduce the sealing effect. When mounting, make sure that no foreign matter or O-ring is twisted during mounting work.
We also recommend that you perform regular maintenance and inspections to see if there is any liquid leakage from the tank. As a guide, check once every six months to one year.
Depending on the operating conditions such as operating temperature, humidity, and pressure, perform the procedure more frequently and reliably.
- 10** The syndiotactic polystyrene resin used for the LLPS series cases and cover materials has excellent chemical resistance to acids and alkalis. However, glass fiber, which is blended as a reinforcing material for syndiotactic polystyrene resin, has a limit in resistance to strong acids and strong alkaline solutions. Therefore, if the skeletal structure of glass fiber is chemically deteriorated by acid or alkali, it will cause cracks in the case or cover.
Solvents of relatively less impact on the product when exposed to high temperatures for long periods of time are aromatic, chlorinated organic, and ketone-based solvents. Be sure to perform the test in the usage environment before using it.
- 11** The material of the O-ring (Φ11 W2.4 mm) for preventing water leakage from the tank when the sensor is mounted is silicone rubber. Silicone rubber is a breathable rubber material, so please evaluate carefully whether this good breathability will affect your equipment before using it.
If the breathability of silicone rubber is a problem, please consider other materials.
- 12** The material of the detection electrode and M10 nut is SUS304.
Stainless steel has excellent corrosion resistance due to the formation of an oxide film on the surface, but it is not perfect.
If chloride ions are present in the liquid, the oxide film may be locally destroyed by foreign matter adhering to the electrode surface or the difference in oxygen concentration of water, and erosion may occur very slowly.
To prevent this erosion, there are measures such as avoiding chloride ions and regularly removing the attached foreign matter, but it is difficult to completely prevent corrosion.
Since general tap water is sterilized with chlorine, it contains chloride ions at a concentration of 0.1 ppm to several ppm. However, the detection of this sensor is not affected because the corrosion progresses very slowly at a very low concentration. Corrosion prevention measures can be examined by selecting appropriate detection electrode and M10 nut materials in consideration of usage conditions.
If you are concerned about the progress of corrosion, please consult with us about changing materials.
Also, for liquid detection of chemicals (acids, alkalis, solvents, oils, etc.), the material of the detection electrode and M10 nut: SUS304 may not be able to withstand the chemicals.
Please use it after being evaluated under the conditions of use and confirming its safety.
- 13** If any substance other than water (acid, alkali, solvent, oil, etc.) is mixed in the detection liquid, be sure to perform a test considering the durability of the silicone rubber before use.
- 14** The detection electrode is fixed, but do not apply unnecessary rotational force.
- 15** Do not pull the cable to apply stress.
Do not put a load on the cable at any time (during storage or use).
When mounting the sensor, firmly fix the cable near the sensor body.
If the cable continues to be stressed, the cable may come off the sensor body or break inside the cable.
- 16** No measures against sulfurization are taken.
If metal parts such as sensors and detection electrodes are sulfurized by sulfur gas generated in hot spring water containing sulfide ions or in an environment where rubber is often used, the sensor may not function.
- 17** As a guide, perform maintenance inspections (daily inspections and regular inspections) once every six months to one year. Depending on the operating conditions such as operating temperature, humidity, and pressure, perform it more frequently and reliably. In addition, remove the deposits inside the tank around the sensor, and visually check for foreign matter in the tank.
- 18** If the detection liquid contains solid matter, the sensor may be damaged if it repeatedly hits the detection electrode (SUS304) or the case of the sensor due to the flow of the liquid.
To use the sensor for a long period of time, remove solids (precipitates / deposits) regularly, check for contaminants, and use a structure that does not allow solids to hit.

Precautions During Use

- 19** This sensor is not explosion-proof.
Do not mount in a dangerous place with flammable or explosive liquids or gases.
- 20** If the coupling capacitance between the primary and secondary is 2,000 pF or less in the DC / DC converter power supply, couple with a capacitance of about 2,200 pF between the primary 0V line and the secondary 0V line.
Also, ensure that the withstand voltage of this capacitor is sufficient according to the usage conditions.
- 21** Since it detects the capacitance with the ground in principle, it cannot be detected accurately when using a battery as the power source. In this case, connect the "+" or "-" of the battery directly to the housing (the one with a large capacity with respect to the ground) or via a capacitor of about 2,200 pF.
Select a withstand voltage value for this capacitor that has sufficient margin for the specifications.
- 22** The operating principle of this sensor is to detect the capacitance between the detection electrode and the ground. When using a switching regulator power supply or a power supply that generates a large amount of common mode noise, be sure to ground the FG terminal of the product equipped with this sensor to suppress the common mode noise that causes malfunction.
When grounding through the housing of the product body, be sure to join (electrically) the connections between machines so that contact resistance does not occur.
Also, when using a power supply that does not have a built-in FG terminal or common mode noise filter, connect the sensor power supply GND (0V) directly or via a capacitor of several μF to the ground.
- 23** If the magnet is brought close to the sensor case, the sensor may malfunction or the detection sensitivity may be affected. When a magnetic field is applied to the sensor, make a thorough verification in advance before deciding whether or not to use it.
- 24** This sensor uses a weak high frequency.
If this sensor receives high frequencies (about 100kHz to 3MHz) electromagnetic waves from ambient equipment, its characteristics may be affected. Check the effects of high frequencies transmitted to this sensor under actual market conditions. If it is affected by peripheral equipment, etc., connect the GND line (0V) of the sensor directly to the housing of the sensor mounting tank or via a capacitor of about 2,200 pF. Use a capacitor with a withstand voltage value that has a sufficient margin for the specifications. Especially when used to a metal tank or a highly conductive liquids, they transmit the previously noted high frequencies (about 100kHz to 3MHz) electromagnetic waves into the inner circuit of this sensor via its detection electrode. Therefore its characteristics are easier to be affected. Check the effects of high frequencies transmitted to the detection electrodes under actual market conditions.
- 25** If you want to freely change the shape or material of the detection electrode, design a new one, or separate between detection electrode and sensor body, consider using our touch sensor (model: HTS-30Z) for the sensor part.
- 26** Before using the sensor, be sure to check the actual operation under actual usage conditions (for example the installation method of the sensor or your product, installation location, and surrounding environment).
Only use after sufficient pre-evaluation, assessment of operation, performance, or reliability in a state representative of use in your product.
Be sure to perform pre-evaluation for the items in advance that are not listed in the specifications.
- 27** Be sure to contact us first if the product is being considered for use in an application which requires extremely high reliability, where its breakage, malfunction, or operation can be reasonably expected to be, directly or indirectly, a significant threat to human life, or can cause injury, or damage to property, including, but not limited to medical equipment, automobiles, aerospace vehicle instruments, nuclear power control equipment or other equipment or instruments. In normal use, be sure to provide safety measures to avoid secondary disasters to ensure the safe operation of the entire system.
- 28** Avoid use and/or storage of the product in a place where it can be exposed to the following; water, oil, chemical solutions, dust, and corrosive gas; abrupt temperature changes; direct sunlight; vibration or shock. Dew condensation or freezing may affect the product performance.

*For other detailed specifications, refer to the specification sheet of the corresponding model.