

# Model LLW-\*\*\*-5V

Capacitive Water Level Sensor  
(For Upper and Lower Limit Detection/Ground Electrode Type/  
Power Voltage : 5 V DC)



Model List	Detection Electrode Length		Operation Status
	Lower Limit / GND Electrode	Upper Limit Electrode	
LLW-205-5V	200 mm	50 mm	Normally open
LLW-2051-5V			Normally closed
LLW-305-5V	300 mm	50 mm	Normally open
LLW-3051-5V			Normally closed
LLW-3020-5V		200 mm	Normally open
LLW-30201-5V			Normally closed

## Application

- Water level control for domestic tap water.
- Water level control for boiling water in water heaters.
- Water level control of pure water, purified water, and distilled water.

## Features

- This sensor can directly detect hot water used in coffee servers and vending machines.
- This sensor can detect two points, the upper limit and the lower limit of the water level, making it ideal for water level control.
- This sensor does not require an external amplifier. Therefore, it is ideal for saving space and reducing the cost of external amplifiers.
- The detection electrode using the anti-polarization capacitor can prevent the electrolytic corrosion of the electrode and realize stable performance for a long period of time.
- The operation LED lights up when the water level is detected.
- By using the ground electrode type, water level can be detected even in a small plastic tank.
- It has high operational reliability against water stains and can be used for a long period of time.

## Rating/Performance

Model	LLW-205-5V	LLW-2051-5V	LLW-305-5V	LLW-3051-5V	LLW-3020-5V	LLW-30201-5V
Standard Detection Target	Tap water or boiling water					
Withstand Pressure Resistance	0.3 Mpa (at atmospheric pressure outside tank: 0.1 Mpa)					
Tank Thickness at Sensor Mounting Point	1 to 2.5 mm					
Power Voltage	5 V DC (Operating voltage range: 4.5 V to 5.5 V DC)					
Power Consumption	18 mA DC or less					
Output	N-channel, MOSFET, Open drain DC30V DC50mA or less at each output					
Output Residual Voltage	1 V DC or less (Load current 50 mA DC at cable 1 m)					
Operation Status	Normally open (On output with the water level detected)	Normally closed (Off output with the water level detected)	Normally open (On output with the water level detected)	Normally closed (Off output with the water level detected)	Normally open (On output with the water level detected)	Normally closed (Off output with the water level detected)
Operation Indication	Lower limit water level: green LED Upper limit water level: red LED (lit when output is ON)					
Response Time	50 ms max					
Temperature Range	-10 to 100 °C (-10 to 65 °C during storage) (Without dew condensation or freezing)					
Humidity Range	95 % RH (85 % RH during storage) (Without dew condensation)					
Breakdown Voltage	500 V AC, 50/60 Hz for 1 min (Between live parts and the mounting nuts)					
Insulation Resistance	50 MΩ or more, at 500 V DC megger (Between live parts and the mounting nuts)					
Vibration Resistance	Durability : 10 to 55 Hz, Double amplitude: 1.5 mm in X-, Y-, and Z-direction, each 2 hours (Device not powered)					
Shock Resistance	Durability : 500 m/s <sup>2</sup> (Approx. 50 G) in X-, Y-, and Z-direction, each 10 times (Device not powered)					
Ingress Protection	IP 67					
Material	Case cover : Polypropylene with glass    Detection electrode : SUS304 Internal O-ring for electrodes : Black EPDM rubber    Gasket : White EPDM rubber The materials used in parts that come into direct contact with water/moisture conform to "Standards for Food Additives" in Japan, defined under the Japan Food Sanitation Law.					
Cable	ø4, 4-core round cord of 0.3 mm <sup>2</sup> and insulation 1.35 mm and 1 m in length (oil and heat resistant)					
Options (sold separately)	PMS-NB24H7G12S (Hexagon nut G1/2 SUS304 Thickness : 7 mm)					
Weight	95 g		115 g		129 g	

## Dimensions

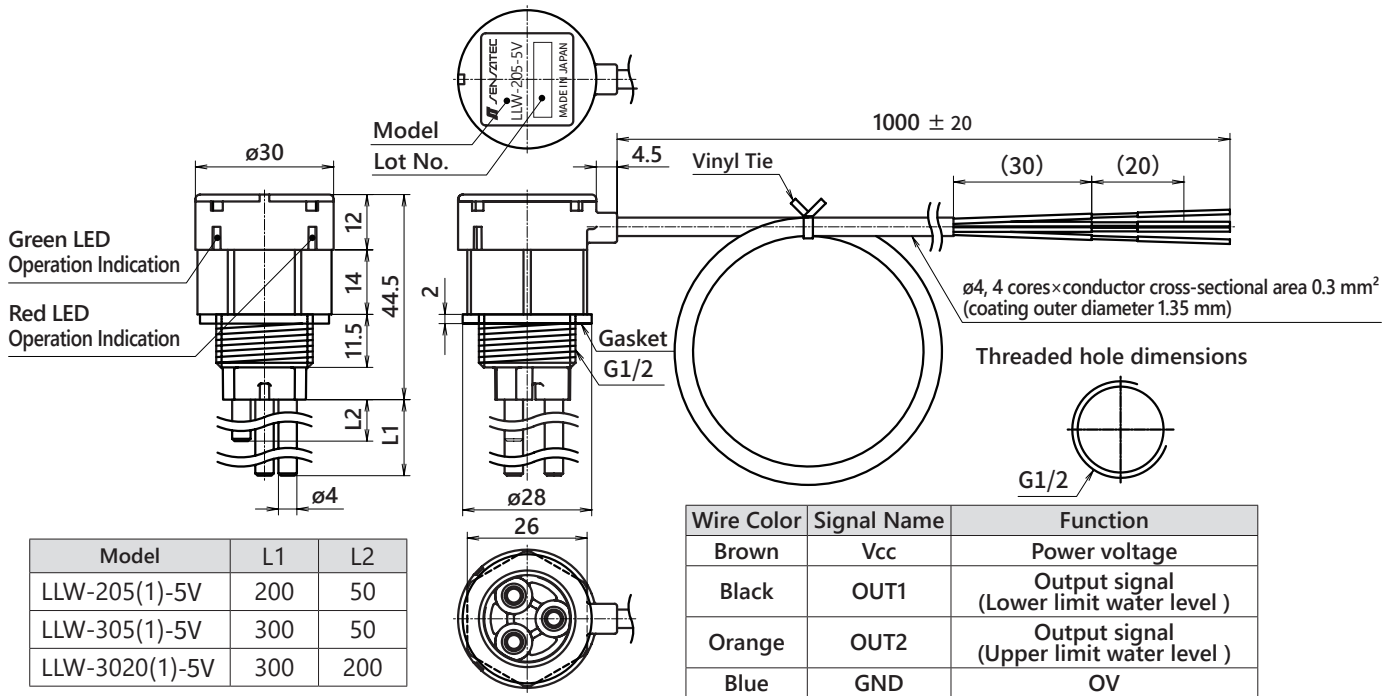

## Output Circuit

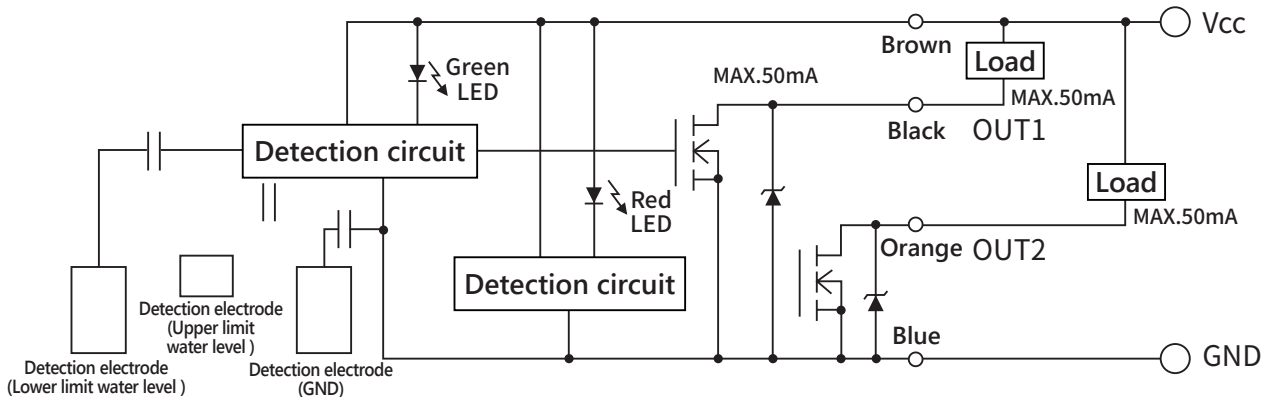

## Precautions During Use

1. This sensor is a vertical mounting type. Please use it by inserting the detection electrode vertically downward from the top surface of the tank.
2. This sensor can directly detect boiling water in a water heater as well as tap water. It can also detect the level of pure water, purified water, and distilled water. However, the water level detected by the sensor rises about 15 mm above the actual water level.
3. Note that this sensor is not designed to detect the levels of liquids with low relative permittivity ( $\epsilon_s$ ), such as ice, alcohol, oil, and others.
4. The output of this sensor may not be restored if water contains highly conductive substances such as salts, acids, and alkaline substances, as well as surfactants and adhesive substances. It is the same as the state where the detection electrode and GND are always electrically connected and short-circuited. Please check the usage carefully before use.
5. When using the sensor in tap water together with a water heater for extended periods, caustic lime and polluted sludge sediment contained in the water will gradually accumulate. The sensor may not recover if there is a lot of unwanted material between the inner wall of the tank and the detection electrode, or between the GND detection electrode and other detection electrodes via the surface where the case electrode is located. Thus, there is a need to be removed and cleaned regularly.
6. Since the three detection electrodes are connected to the circuit section, do not apply a voltage higher than the rated power supply voltage to the electrode section. Make sure that the DC power supply for the sensor has sufficient dielectric strength between water and the commercial power supply before use.
7. Be sure to tighten the G1/2 nut (sold separately) for mounting with a torque of  $1.5 \text{ N} \cdot \text{m}$  ( $15.4 \text{ kgf} \cdot \text{cm}$ ) or less.
8. Although the detection electrode is fixed, never apply rotational force to it. Also, do not apply stress or bend the electrodes. Do not pull the cable.
9. Multiple sensors cannot be used in the same tank due to mutual interference. If you need to use multiple sensors, be sure to consult.
10. The case cover material is made from glass-filled polypropylene and should not be used in environments where liquids containing oxidizing agents (peroxides, persulfate salts, permanganate salts), especially (soft) etching liquids, peeling liquids are in use.
11. The length of the detection electrode can be freely cut and adjusted. When changing the length of the detection electrodes, make the lengths of the two longer detection electrodes the same.
12. Please contact us if you wish to change the length of the detection electrode or the material of the component.
13. When detecting hot water such as boiling water, use a heat insulating material between the sensor case and the tank to suppress the temperature rise of the sensor case. The reliability of the sensor built-in parts is improved, and the failure rate during long-term use can be reduced.
14. Because there is no reverse connection protection diode built-in, pay careful attention to the polarity of the power supply.