

Model HLG-6,8,X-5 Ultra-small Capacitive Touch Sensor with Common-mode Noise Rejection (Locked connector type) (Low sensitivity type)

PATENTED



▶ HLG-6-5
▶ HLG-8-5
▶ HLG-X-5

Normally open
Standard



▶ HLG-6B-5
▶ HLG-8B-5
▶ HLG-XB-5

Normally open
Shifted Frequency



▶ HLG-61-5
▶ HLG-81-5
▶ HLG-X1-5

Normally closed
Standard



▶ HLG-61B-5
▶ HLG-81B-5
▶ HLG-X1B-5

Normally closed
Shifted Frequency

Model List	Operation Sensitivity	Operation Configuration	Frequency
HLG-6-5	60 pF	Normally open	Standard
HLG-8-5	80 pF		
HLG-X-5	100 pF		
HLG-6B-5	60 pF		Different
HLG-8B-5	80 pF		
HLG-XB-5	100 pF		
HLG-61-5	60 pF	Normally closed	Standard
HLG-81-5	80 pF		
HLG-X1-5	100 pF		
HLG-61B-5	60 pF		Different
HLG-81B-5	80 pF		
HLG-X1B-5	100 pF		

Application

- Touch switch for door knobs
- Elevator switch
- Touch switch for automatic doors
- Touch switch for security purpose
- Seat sensor
- Input switch for electric devices
- Input sensor of amusement equipment
- Safety device for finger pinch avoidance from machine moving parts or door mechanisms

Features

- A locking connector securely prevents disconnection of connectors caused by running wires or vibration. A clear click touch when plugging together ensures a secure insertion.
- When used in a large-output transmission station or near a large-sized inverter device, the common mode noise from the DC power source can be diverted to the frame ground.
- Because this is an ultra-small sensor, it can be easily installed locations where space is very limited.
- Open collector output means direct connection to a microcomputer input is possible without any special interface circuit.
- The sensor does not react to objects of small capacitance such as plastic bags or small pieces of luggage. There is no need to adjust the sensitivity level.
- The static electricity generated by human activity is countered by built-in protection circuits. No additional countermeasures are required.
- The sensor features a contact terminal for the touch electrode. Connection is available by the simple connection of a touch electrode.

Rating/Performance

Model	HLG-6-5	HLG-8-5	HLG-X-5	HLG-61-5	HLG-81-5	HLG-X1-5
Operation Sensitivity	60 pF±12 pF	80 pF±16 pF	100 pF±20 pF	60 pF±12 pF	80 pF±16 pF	100 pF±20 pF
Power Voltage	4.75 V to 5.5 V DC					
Power Consumption	15 mA DC or less (At 5 V DC)					
Output	NPN transistor open collector 14.4 V DC, 50 mA DC or less					
Maximum Output Saturation Voltage	1 V DC MAX (Load current 50 mA DC)					
Operation Status	Normally open (On output with detection target)			Normally closed (Off output with detection target)		
Temperature Range	-20 to 60 °C (-25 to 65 °C during storage) (Without dew condensation or freezing)					
Humidity Range	35 to 85 % RH (25 to 85 % RH during storage)					
Anti-static Electricity	With/without F.G. terminal (Frame Ground) Contact discharge or discharge in air between the contact terminal and the ground terminal : ± 25 kV (150 pF, 330 Ω, 20 times at 1 second interval)					
Breakdown Voltage	500 V AC, 50/60 Hz for 1 min (Between live parts and the case)					
Insulation Resistance	20 MΩ or more, at 500 V DC megger (Between live parts and the case)					
Vibration Resistance	Durability : 10 to 55 Hz, Double amplitude: 1.5 mm in X-, Y-, and Z-direction, each 2 hours (Device not powered)					
Shock Resistance	Durability : 500 m/s ² (Approx. 50 G) in X-, Y-, and Z-direction, each 3 times (Device not powered)					
Ingress Protection	IP50					
Case Material	PBT reinforced with glass-fiber (Ivory)			PBT reinforced with glass-fiber (Blue)		
Connector	Connector : SM04B-GHS (4-pin), Housing : GHR-04V-S, Contact : SSSL-002T-P0.2 (from J.S.T. Mfg. Co., Ltd.)					
Weight	Approx. 1.5 g					
Options (Sold Separately)	Connector harness: CNH-GHR04S28-300					

Dimensions

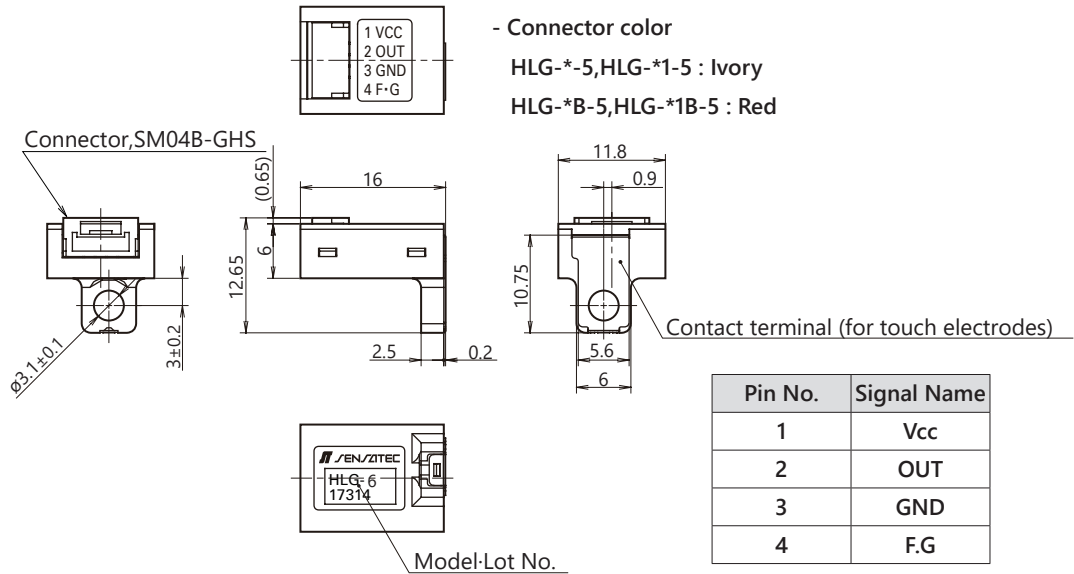

Output Circuit

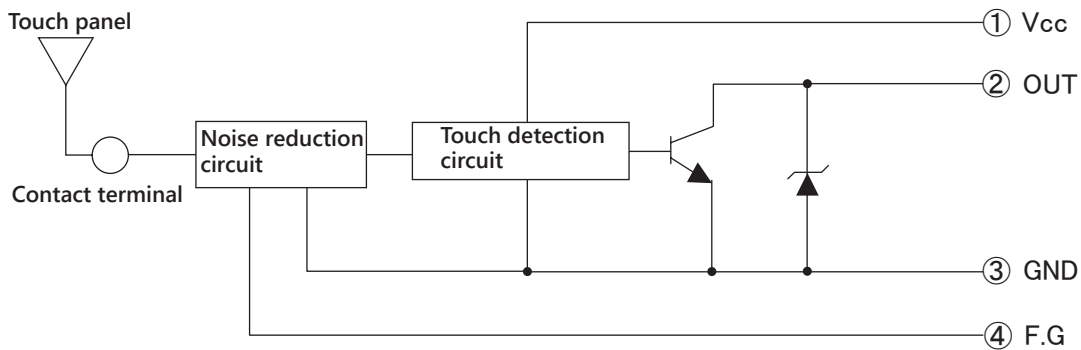

Precautions During Use

- Do not apply any voltage greater than 100 V peak, between GND and F.G
- The touch (detection) electrode of the touch sensor is connected to the detection circuit. Accordingly, between the touch sensor power and AC power, ensure the insulation is sufficient for the breakdown voltage for safety.
- When the coupling capacitance between the primary and the secondary power in the DC-DC converter power supply is 2000 pF or less, the capacitance between the primary 0 V line and the secondary 0 V line should be approximately 2000 pF. Ensure the capacitor has a sufficient breakdown voltage.
- The touch sensor detects the capacitance to ground. If the power source is a battery, connection should be either directly made with a high current capability of either the plus or minus side to the ground (such as a housing), or there should be a capacitor fitted of approximately 2000 pF.
- The touch sensor uses a high-frequency oscillator circuit.
If multiple touch sensors are approached or the same person touches the touch electrodes of multiple touch sensors, mutual interference may occur which could reduce detection accuracy.
- To prevent mutual interference, models using oscillators of differing frequencies are used.
For the Shifted Frequency types, either B, C, D, or E is included after the model name.
The influence of mutual interference depends on the arrangement of the touch sensor and touch electrode as well as the wiring status; consult us for the details.
- If the F.G. terminal is not to be used, open status is required. In this case, the sensor can still be used as a normal touch sensor.
- When using the normal open output type, be sure to use the sensor with the wiring capacity of the output line under 1,000 pF. Otherwise, the charge of the output line may exceed the maximum output current at output drive, resulting in output malfunction.
When a longer output wiring is needed for larger output wiring capacity over 1,000 pF, either add a 100 Ω resistor in series besides the output terminal of the sensor side, or use the normal close output type.
- For normally open output-type sensors, the output line wiring length should be 5 m or less in order to eliminate the influence of the output drive current capability of the IC used in this sensor and the anti-static performance due to wiring inductance.
- The tightening torque for the case should be 0.5 N·m or less.
- For other precautions, refer to "General Precautions" for touch sensors.